

Colorado Department of Transportation Staff Bridge Bridge Detail Manual	Chapter: 15.1 Effective: June 30, 2024 Supersedes: July 23, 2013
---	--

Wall Details

15.1.1 Purpose

These drawings are to graphically present all pertinent information necessary for the construction of walls as well as depict constructability and ROW issues. Some of these wall types include:

- A) Cast-in-Place (CIP)
- B) Mechanically Stabilized Earth (MSE)
- C) Soil Nail
- D) Caisson
- E) Sound Barrier
- F) Other types – Sheet Pile, Gabion, gravity, semi-gravity, etc.

Close cooperation with the Roadway design group is essential for proper layout of the walls. The Wall Layout is an iterative process between the Roadway and Bridge groups. Preliminary layout from Roadway is used to begin the wall design which determines excavation limits and other critical items. These items can then be used by Roadway to revise the layout as necessary based on recommendations and input from the Bridge group. The following figure depicts a possible constructability issue between an off-ramp wall and the adjacent County Road. By depicting the excavation limits and other items in the drawings, constructability issues can be identified and resolved early in the design process. Costly construction issues and field revisions can thereby be avoided.

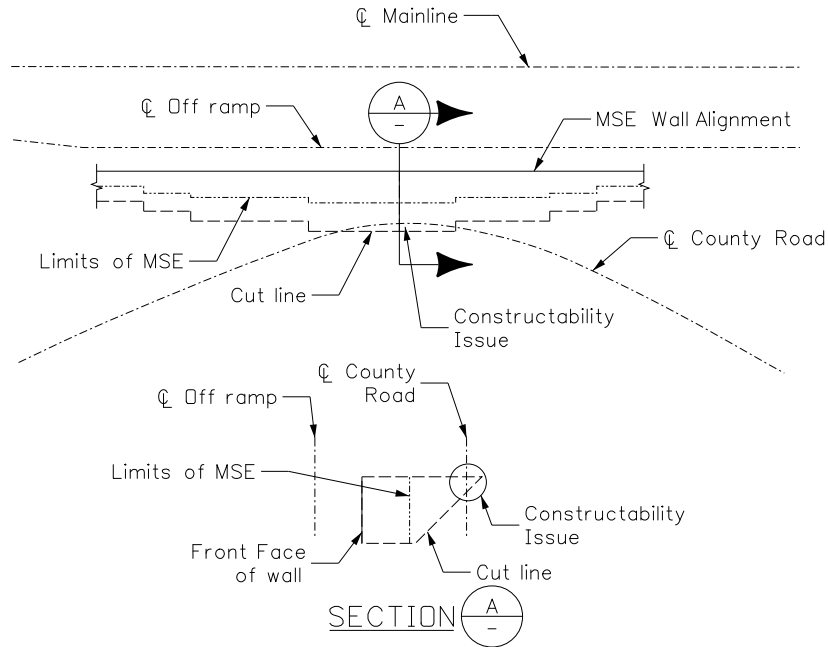

Fig. 15.1.1-1 Wall Conflict Example

15.1.2 Responsibility

These drawings shall be prepared and checked in the Design Unit. The graphical presentation of information on these drawings shall be the responsibility of the individual preparing the drawings.

15.1.3 Scales

Standard Architectural and Civil scales shall be used that are suitable to make the details legible on a standard sheet.

15.1.4 Orientation of Details

The PLAN of the wall shall be placed, if possible, at the upper left of the sheet with the layout line parallel to the border. The ELEVATION of the wall shall be projected below the PLAN when possible. Elevations should include vertical scales. The PLAN and ELEVATION shall be oriented so the front face of the wall will be shown in the ELEVATION whether the resulting stationing is shown increasing or decreasing on the sheet. Sections shall be placed to the right of the PLAN and ELEVATION. If space is limited, the sections or additional details may be shown on another sheet. Generally, sections should be taken from the PLAN and ELEVATION rather than from secondary views or other sections.

15.1.5 Control

The horizontal control line (HCL) for the wall shall be identified including all angle points, intersection angles, etc. Whether the wall is top controlled or bottom controlled shall be made clear. The wall layout can be controlled using its own horizontal control line, by using stations and offset from the mainline HCL or by using coordinates. The vertical control should be depicted in the elevation views. If the vertical control is based on the roadway vertical profile, reference elevations should be included in the elevation views for aiding construction as well as quantity calculations.

15.1.6 Dimensions

A sufficient number of dimensions and elevations shall be shown on the details to provide adequate information necessary in the checking of the plans and the construction and/or design of the wall. Quantities should be able to be verified based on plan dimensions. Length and location of wall steps should account for wall panel length and staggers as well as assumed corner dimensions.

15.1.7 Worksheets

The use of the Bridge Worksheets is encouraged, but the designer shall verify the dimensions and applicability of the worksheet for the required application.

15.1.8 Check Items for All Wall Types

Listed below is a summary of items that shall be checked and appear on the drawing for all wall types as applicable. See specific wall types in sections 15.1.9 through 15.1.14 for additional information as required. Wall drawings should show sufficient information in order to check shop drawing information provided by the Contractor. Additional information shall be shown as required for the project as well as for the individual wall type.

CHECK ITEMS

- A) Identify Horizontal Control Line.
- B) Identify Vertical Control Line or information.
- C) Identify concrete coating (color) limits and/or rustications.
- D) Identify limits of concrete sealer.
- E) Delineate approximate construction or excavation limits.
- F) Show assumed wall steps in elevation view. Length and location of wall steps should account for assumed wall panel or block length and staggers as well as assumed corner dimensions.

- G) Show weep hole/drain hole locations in elevation views.
- H) Show surface drainage plan to avoid water coming over the wall.
- I) Locate interferences or special details such as light supports.
- J) Depict and show interferences for wall in elevation views such as drains, abutments.
- K) Provide isometric views for difficult intersections such as at abutments or angle points as required to clarify the areas.
- L) Show all known utilities and utility crossings.
- M) Show utility details of conduits entering/exiting walls.
- N) Show locations of changes in typical section.
- O) Show proposed grade at front face of wall and top of wall as applicable.
- P) Show existing grade at front face of wall and indicate if other than front face.
- Q) Show bedrock or soil information which affect wall design.
- R) If walls are not associated with a bridge plan set, the name and direction of the nearest town shall be provided at the beginning and end of the wall.
- S) Show finished contour lines when they are available.
- T) Show standard North Arrow
- U) Show type of slope protection above and/or below the wall as applicable.
- V) Show direction and rate of fill or cut slopes. Show approximate location of toe and top of slopes.
- W) Show existing and proposed structures, label with structure number, and note if the existing structure is to be removed.
- X) Provide matchlines for walls which extend to multiple sheets. Matchlines should be placed to avoid critical section changes or alignment changes in the wall.
- Y) Show ROW limits if available.
- Z) Provide Design information and constraints, e.g. Ground Water levels, allowable bearing capacity, allowable differential settlement, fill material properties, allowable long-term wall settlement, tolerance on vertical and horizontal position of the wall control line.

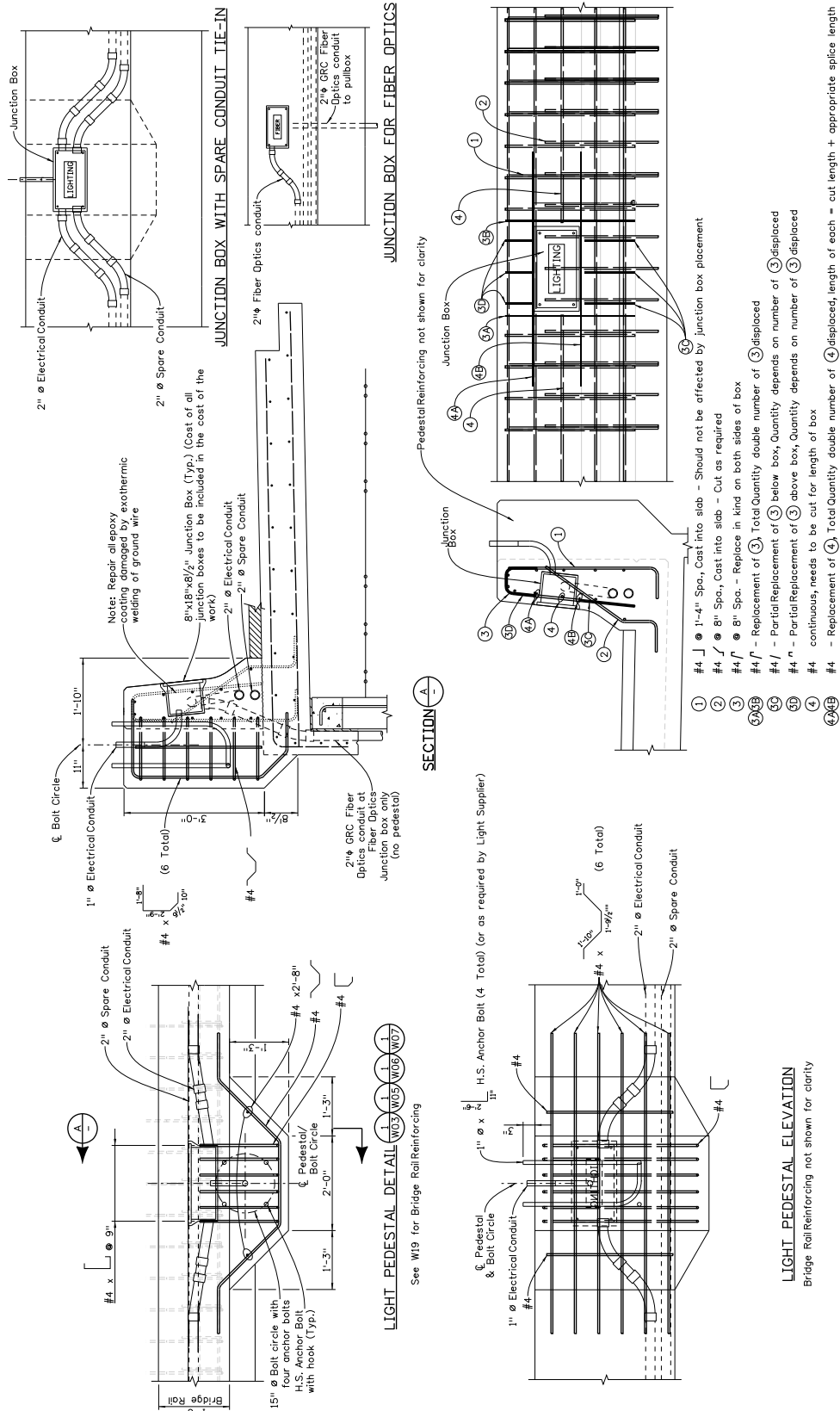

Fig. 15.1.8-1 Light Pedestal Example

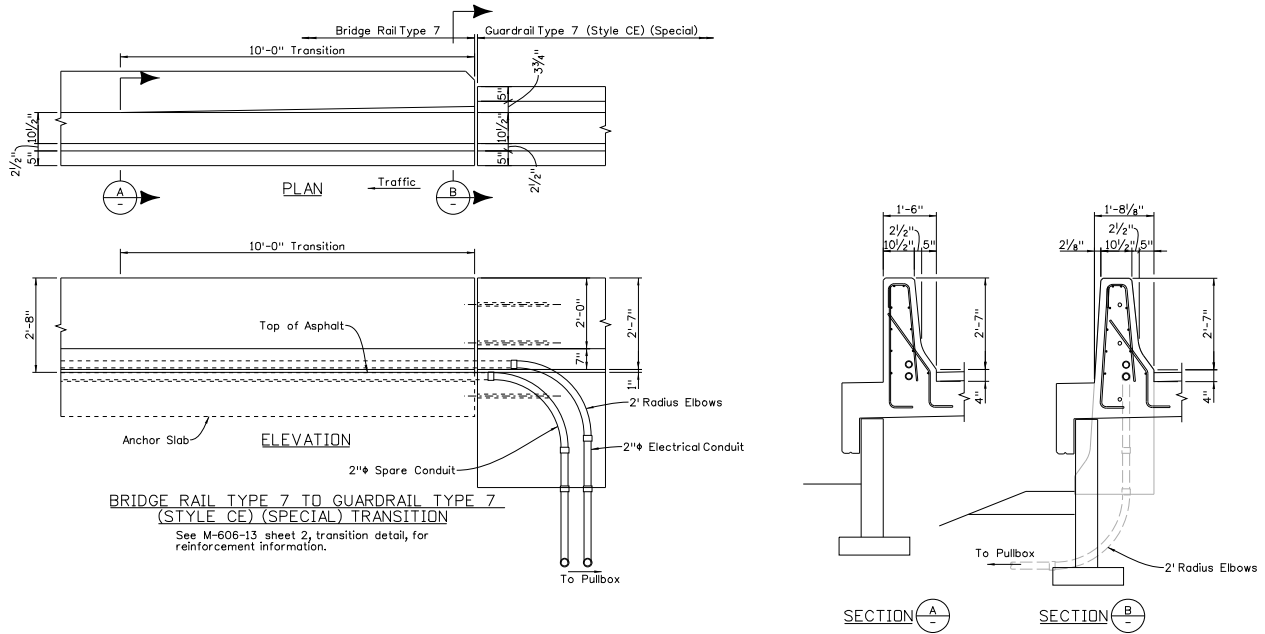

Fig. 15.1.8-2 Conduit Detail Example

15.1.9 Cast-In-Place Wall Examples & Check Items

Listed below is a summary of items that shall be checked and appear on the drawing in addition to the General Items listed in Section 15.1.8. Additional information shall appear, as required. The wall examples shown here are a guide only; each wall shall be evaluated for applicability of examples and worksheets on a case by case basis.

CHECK ITEMS

- A) Layout and depict weakened plane and expansion joints in elevation views.
- B) Show Footer layouts.

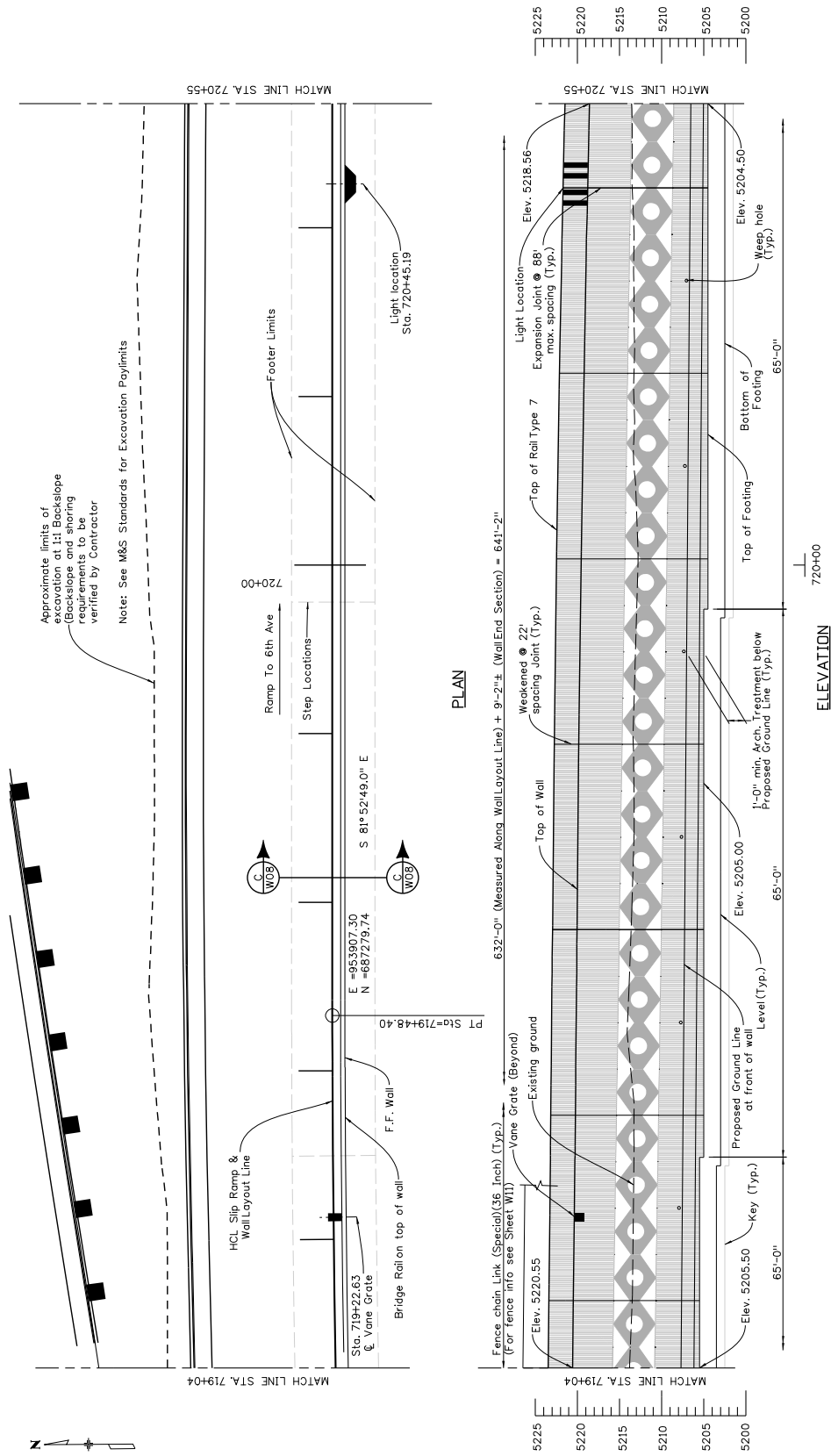
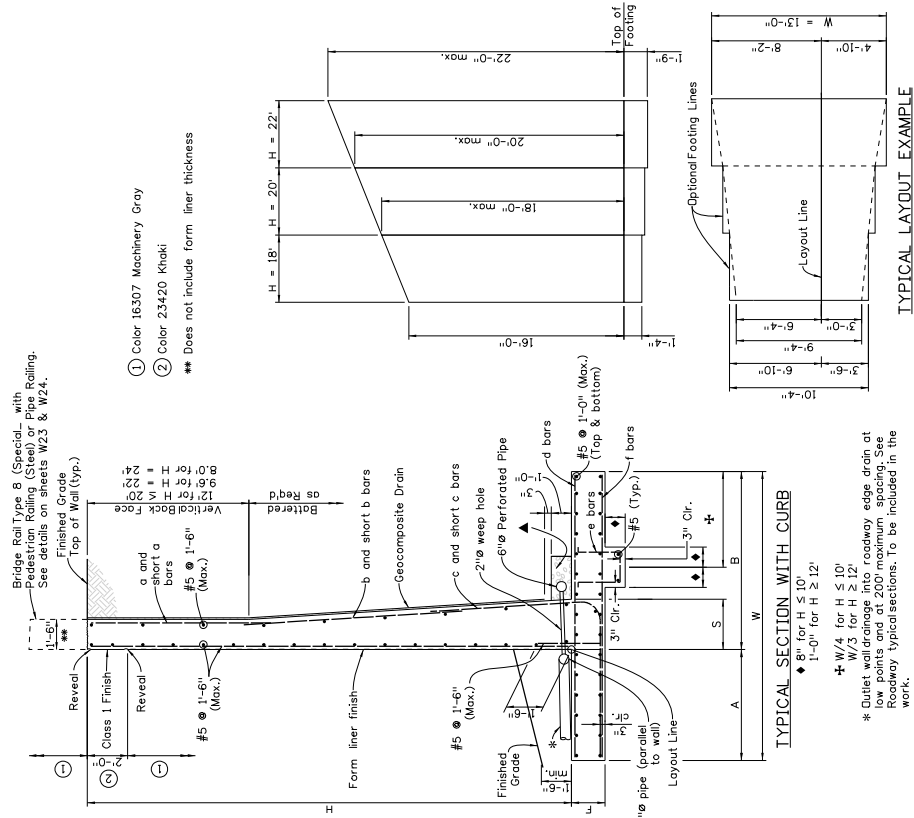

Fig. 15.1.9-1 Cast In Place Example



▲ 1.0 CF Filter Material (Class B) wrapped in Geotextile (Coverage) Class 1, 2 weep hole at 20' intervals (2' coverage) Class 1, 2 weep hole at 60' intervals. To be included in the work.

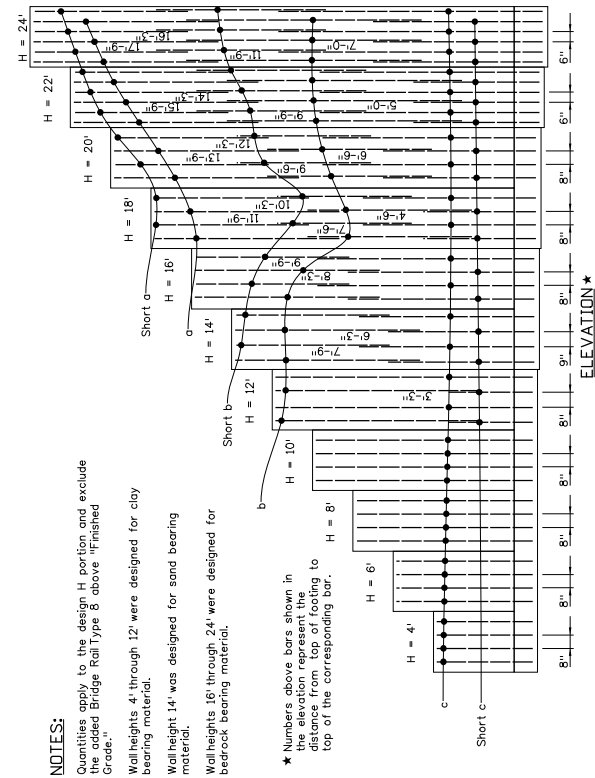

TABLE OF REINFORCING STEEL DIMENSIONS AND DATA

H	4'	6'	8'	10'	12'	14'	16'	18'	20'	22'	24'
W	3'-9"	5'-9"	8'-0"	11'-6"	14'-3"	9'-4"	9'-4"	10'-4"	11'-8"	13'-0"	14'-4"
A	1'-0"	1'-9"	3'-0"	7'-0"	10'-6"	3'-0"	3'-0"	3'-6"	4'-2"	4'-10"	5'-6"
B	2'-9"	4'-0"	5'-0"	4'-6"	3'-9"	6'-7"	6'-4"	6'-10"	7'-6"	8'-2"	8'-10"
F	1'-0"	1'-0"	1'-2"	1'-4"	1'-4"	1'-4"	1'-4"	1'-4"	1'-4"	1'-9"	2'-0"
S	1'-6"	1'-6"	1'-6"	1'-6"	1'-6"	1'-6"	1'-6"	1'-6"	1'-6"	1'-6"	2'-6"
Batter	-	-	-	-	-	1/2:12	1/2:12	1/2:12	1/2:12	1/2:12	1/2:12
a bars	-	-	-	-	-	#5 @ 8"	#5 @ 8"	#5 @ 8"	#5 @ 8"	#5 @ 8"	#5 @ 6"
b bars	-	-	-	-	-	#5 @ 8"	#5 @ 8"	#5 @ 8"	#5 @ 8"	#5 @ 8"	#5 @ 6"
c bars	#5 @ 8"	#5 @ 8"	#5 @ 8"	#5 @ 8"	#5 @ 8"	#5 @ 8"	#5 @ 8"	#5 @ 8"	#5 @ 8"	#5 @ 8"	#5 @ 6"
d bars	#5 @ 8"	#5 @ 8"	#5 @ 8"	#5 @ 8"	#5 @ 8"	#5 @ 8"	#5 @ 8"	#5 @ 8"	#5 @ 8"	#5 @ 8"	#5 @ 6"
f bars	#5 @ 8"	#5 @ 8"	#5 @ 8"	#5 @ 8"	#5 @ 8"	#5 @ 8"	#5 @ 8"	#5 @ 8"	#5 @ 8"	#5 @ 8"	#5 @ 6"
Stem Bars	8	10	14	16	18	22	24	26	30	30	32
Factored Toe Press	1.52	1.52	1.56	1.59	1.54	3.21	5.22	5.55	5.75	5.91	6.15
Steel/b/ft	41.3	55.1	75.68	104.65	166.18	121.13	161.28	203.00	265.12	365.28	409.42
Conc. CY/ft	.394	.579	.823	1.086	1.403	1.312	1.436	1.612	1.925	2.292	2.765

③ Total number of longitudinal #5 bars in stem.

④ These quantities do not include additional concrete and reinforcing at footing steps. See W25 for details.

⑤ Wall height not designed for collision.

Fig. 15.1.9-2 Cast In Place Example

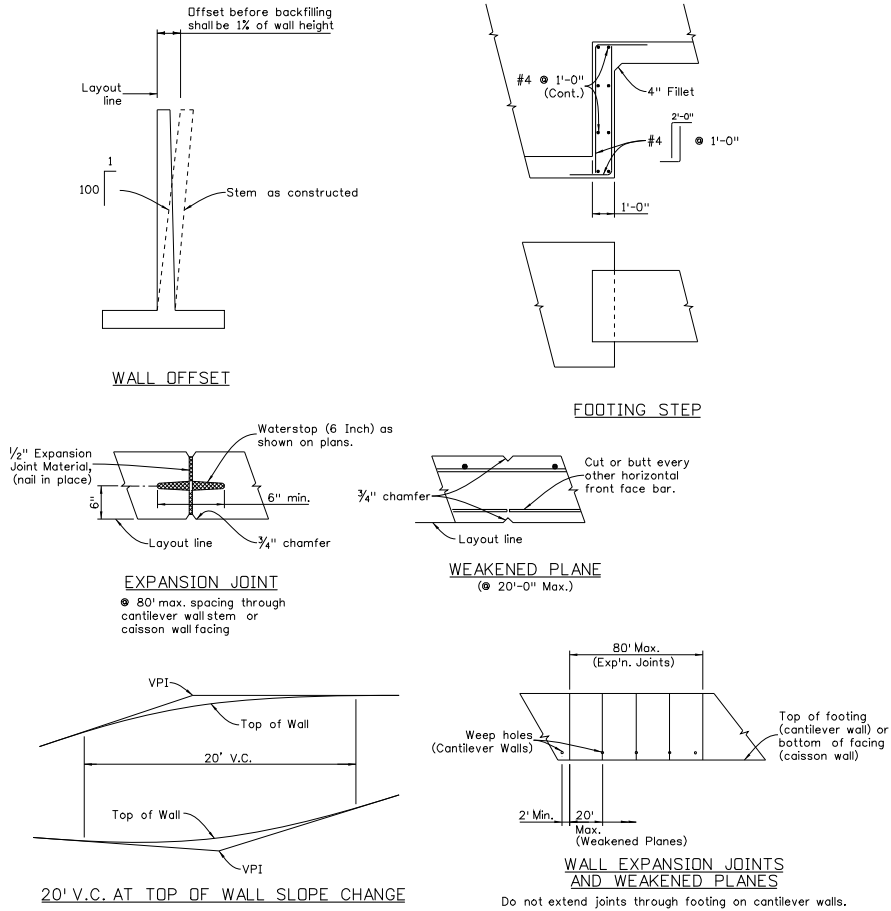

Fig. 15.1.9-3 Cast In Place Details

15.1.10 MSE Wall Examples & Check Items

Listed below is a summary of items that shall be checked and appear on the drawing in addition to the General Items listed in Section 15.1.8. Additional information may appear as necessary to fully depict required work. The wall examples shown here are a guide only; each wall shall be evaluated for applicability of examples and worksheets on a case by case basis.

Check Items

- A) Delineate approximate limits of MSE area (strap lengths) in the plan view.
- B) Define top of block or panel height at 20' intervals (max.) or define using curve or vertical profile. Elevations shown on the elevation are preferred, but the elevation information may be presented in table form as well.
- C) Show assumed/conceptual plan for water collector system and wall outlets.
- D) Depict and show interferences for wall straps in elevation views such as drains and abutments.

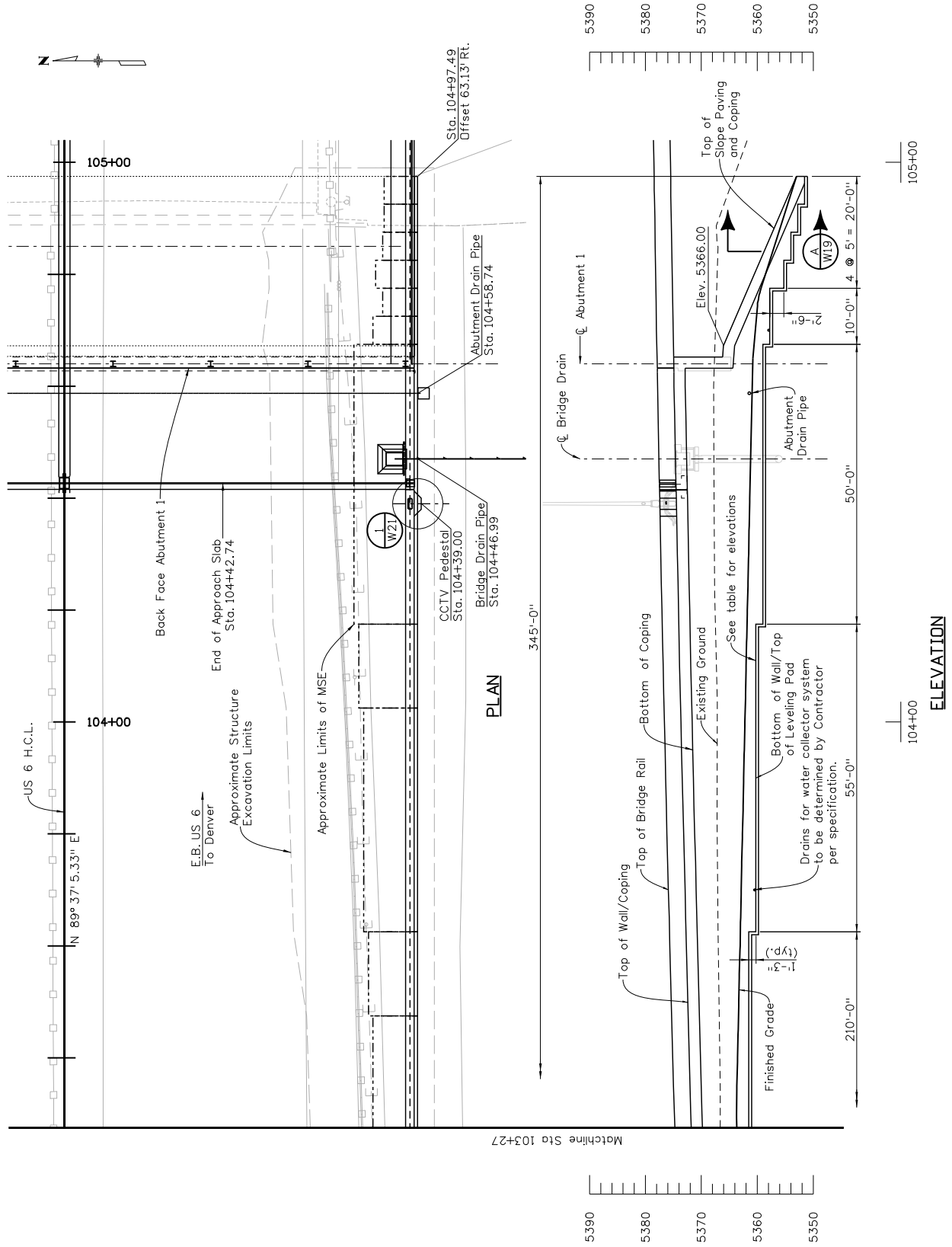

Fig. 15.1.10-1 MSE Wall Example 1

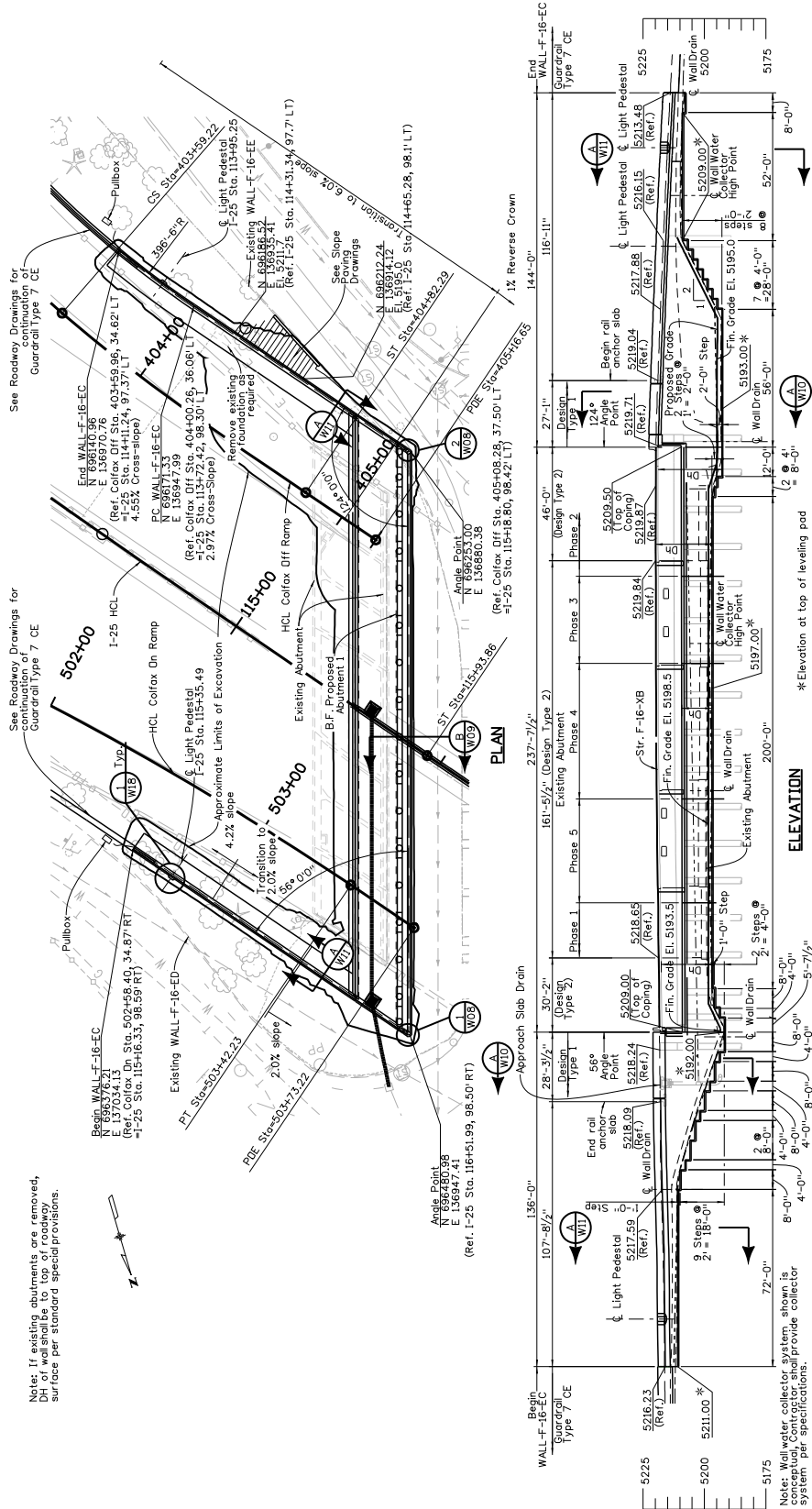

Fig. 15.1.10-2 MSE Wall Example 2

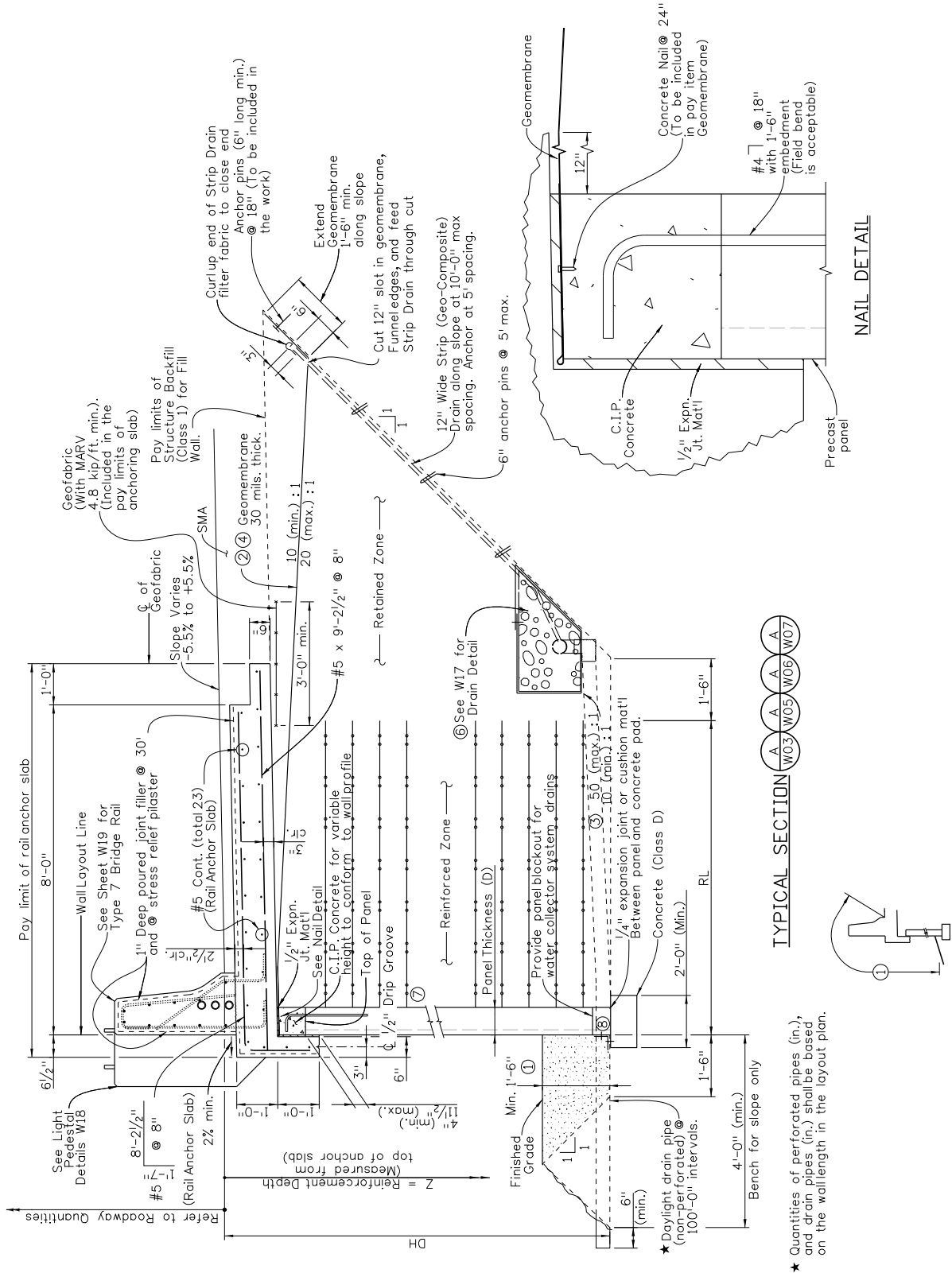
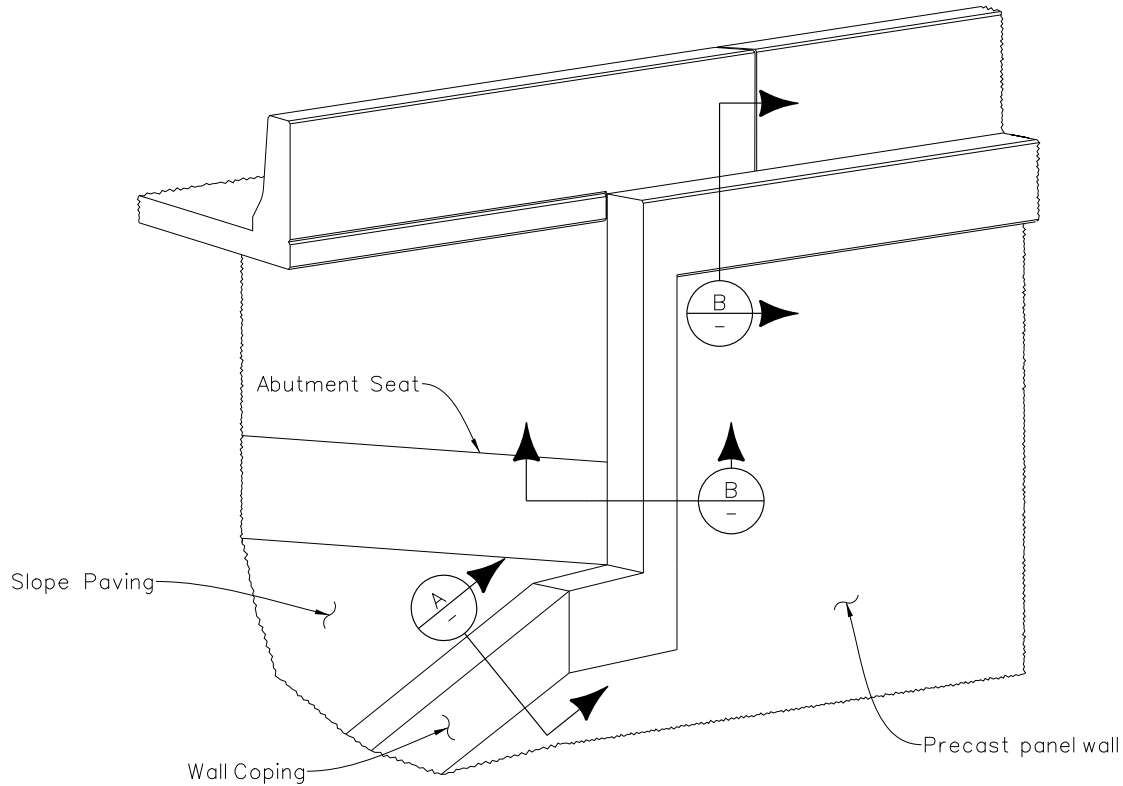

Fig. 15.1.10-3 MSE Wall Section Example

★ Quantities of perforated pipes (in.), and drain pipes (in.) shall be based on the walllength in the layout plan.

① Color No. 364440 (Light Gray)



ISOMETRIC DETAIL AT CORNERS
Northeast Corner shown, other corners similar

Fig. 15.1.10-4 Additional Detail Example

15.1.11 Soil Nail Wall Examples & Check Items

Listed below is a summary of items that shall be checked and appear on the drawing in addition to the General Items listed in Section 15.1.8. Additional information may appear as necessary to fully depict required work. The wall examples shown here are a guide only; each wall shall be evaluated for applicability of examples and worksheets on a case by case basis.

CHECK ITEMS

- A) Define spacing (vertical and horizontal), size and length of soil nails.
- B) Depict limits of nails in plan view.
- C) Locate interferences for soil nails.
- D) Check overhead clearance or limitations for soil nail equipment.
- E) Show test nail, proof nail and verification nail locations.
- F) Verify soil nail angle is provided.
- G) Show special conflict details as necessary.
- H) Provide design criteria such as bond strength.

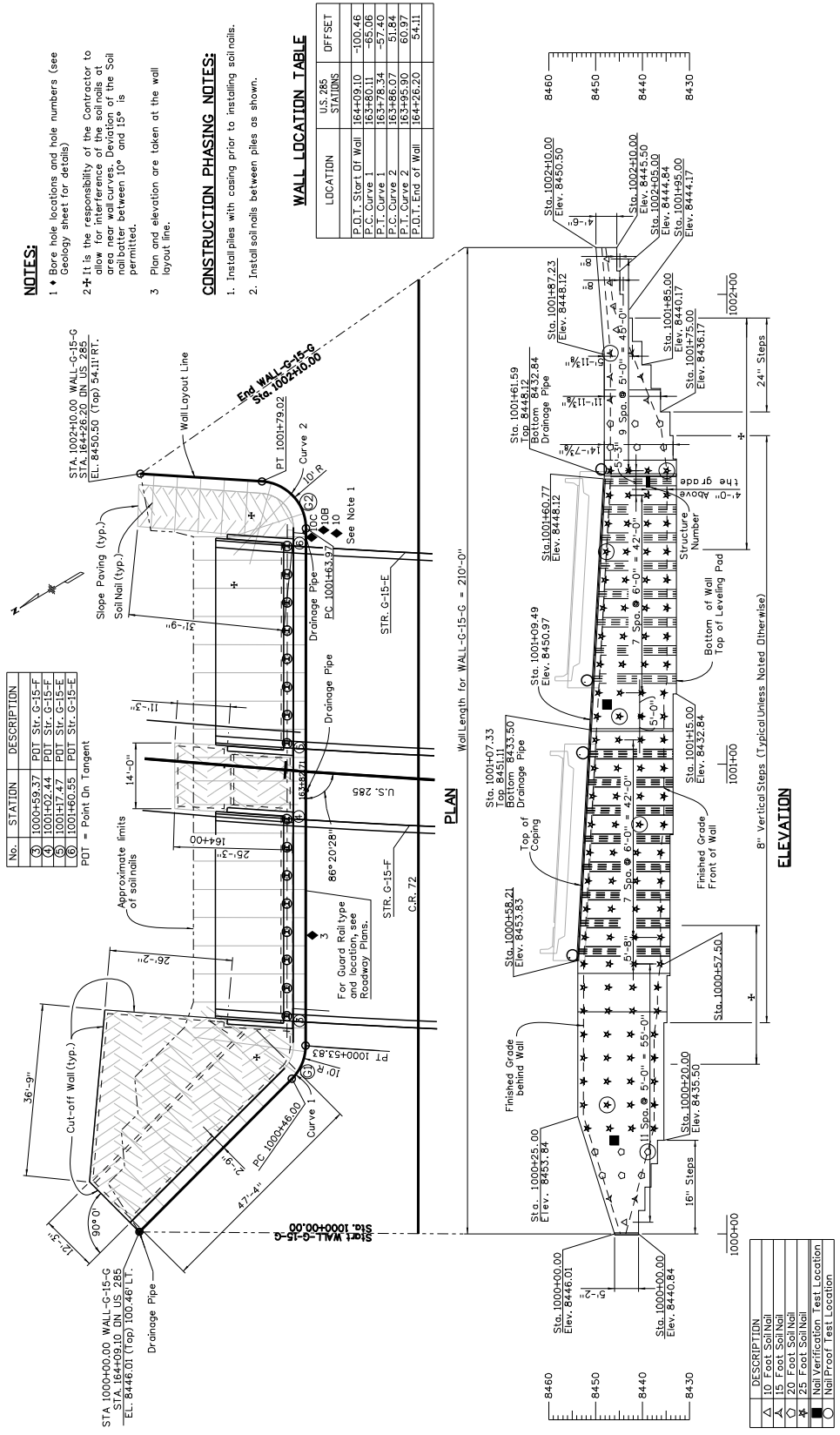

Fig. 15.1.11-1 Soil Nail Wall Example

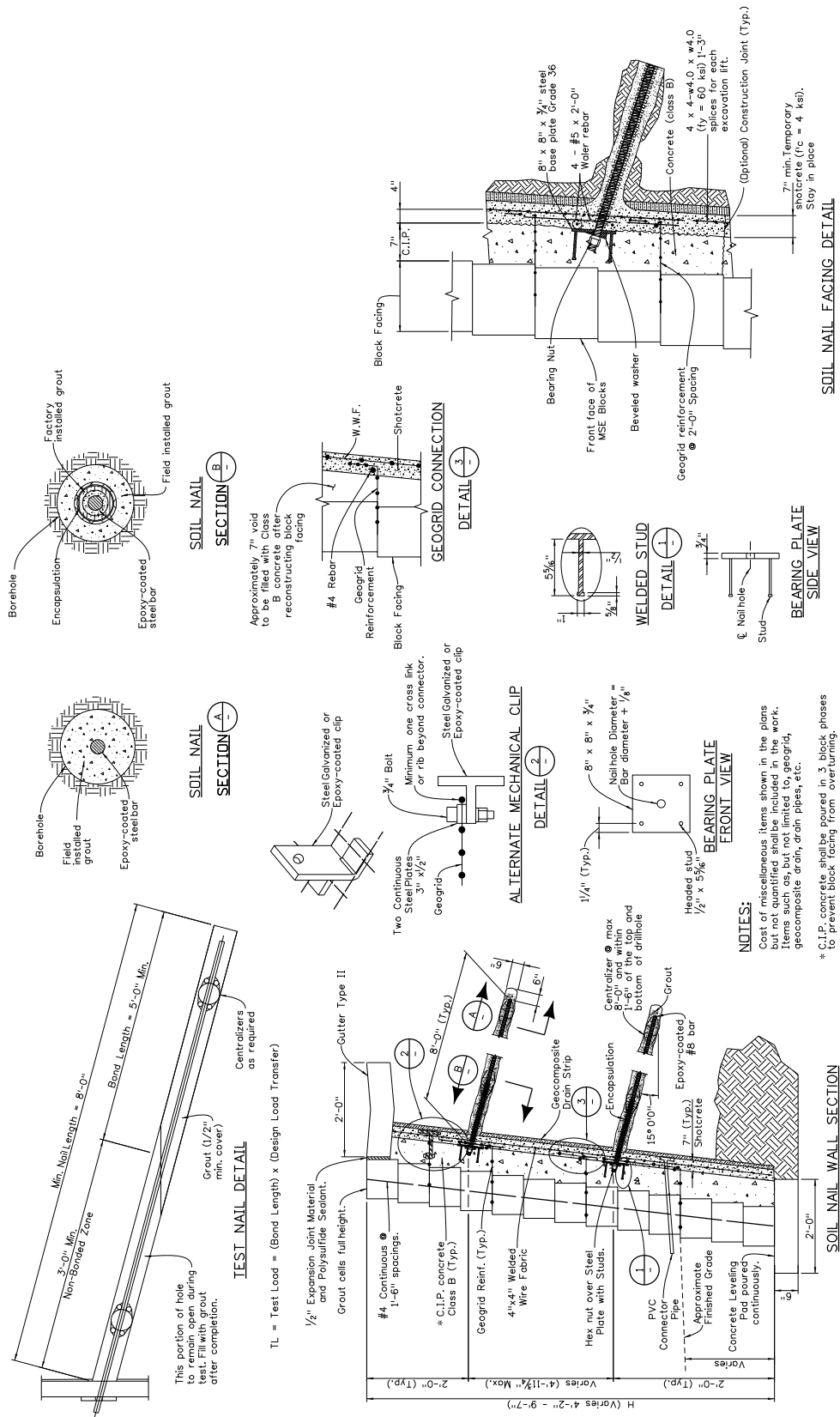

Fig. 15.1.11-2 Soil Nail Details Example

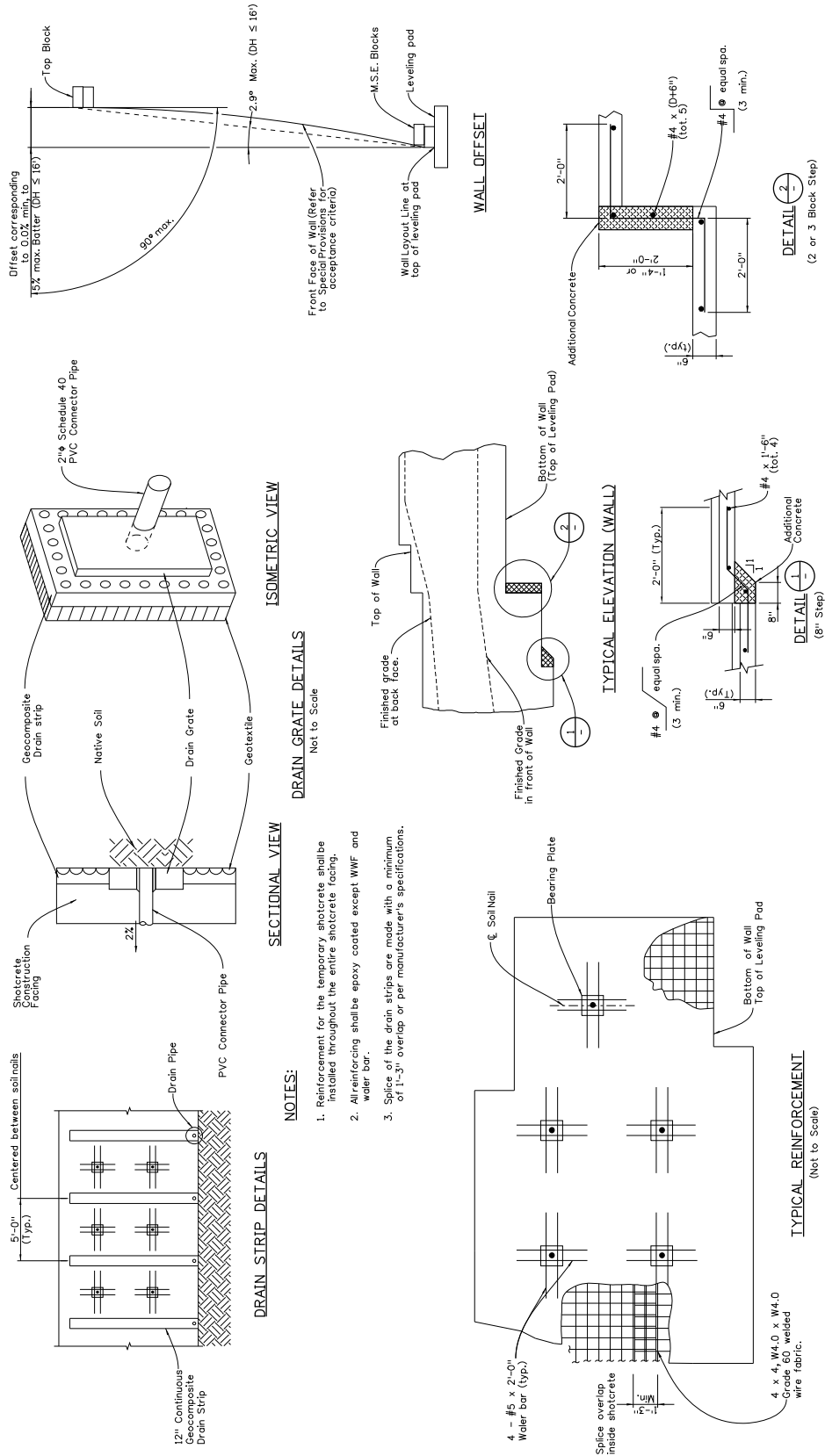

Fig. 15.1.11-3 Soil Nail Details Example 2

15.1.12 Caisson Wall Examples & Check Items

Listed below is a summary of items that shall be checked and appear on the drawing in addition to the General Items listed in Section 15.1.8. Additional information shall appear, as required. The wall examples shown here are a guide only; each wall shall be evaluated for applicability of examples and worksheets on a case by case basis

CHECK ITEMS

- A) Provide Facing wall connections.
- B) Provide "In-between" caisson details.
- C) Include Drilling/placement notes for secant caissons.

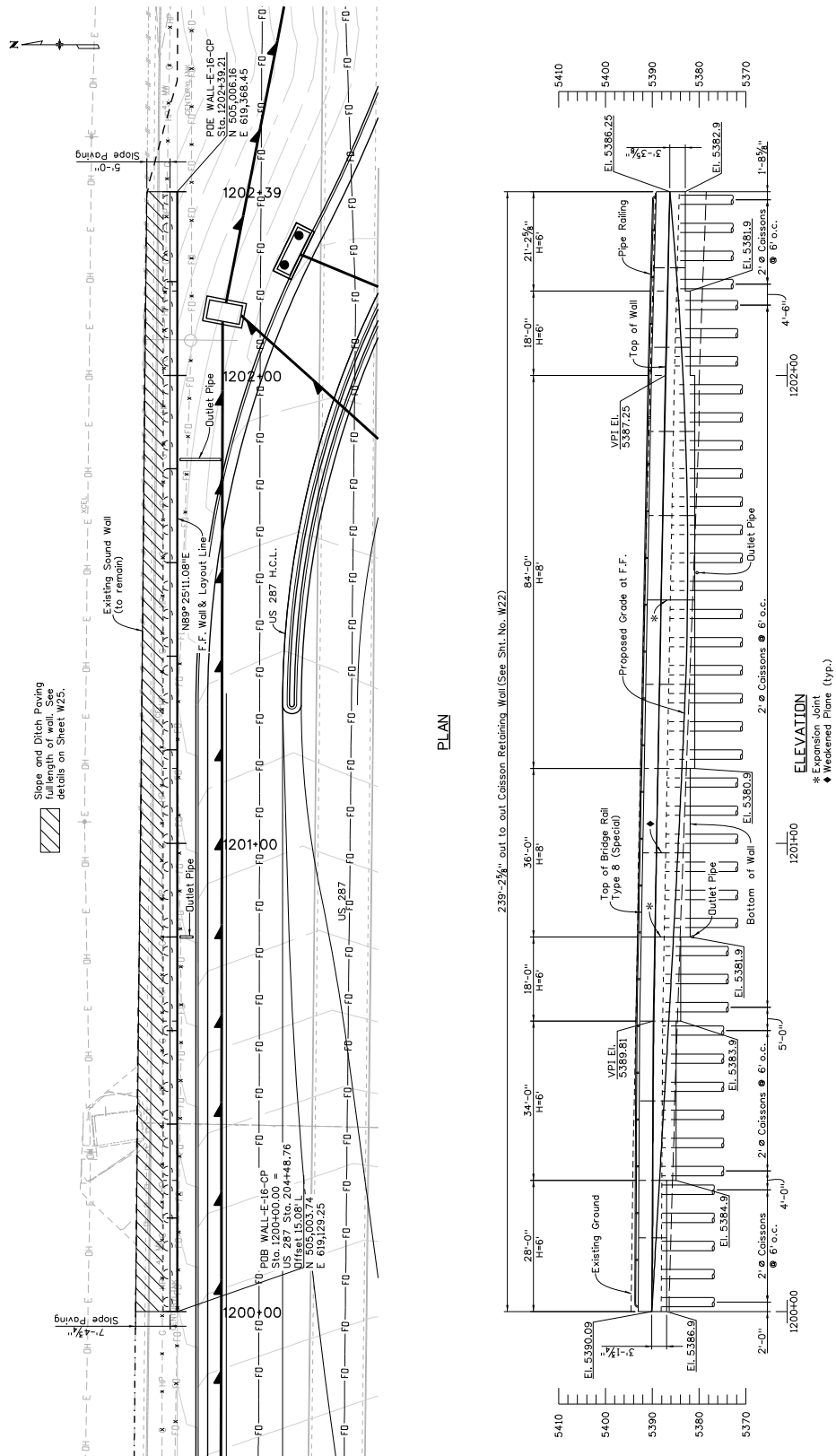

Fig.15.1.12-1 Caisson Wall Layout Example

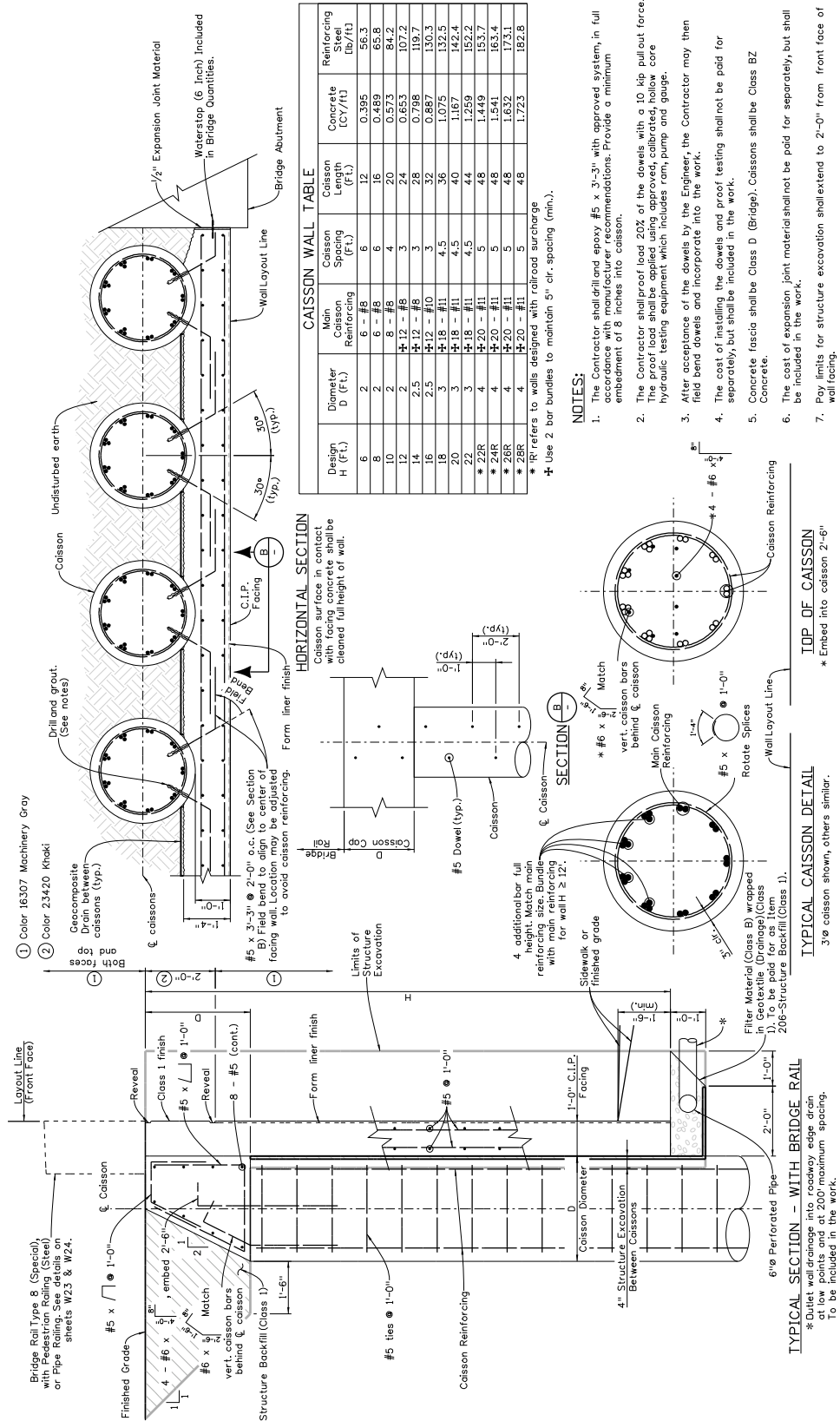
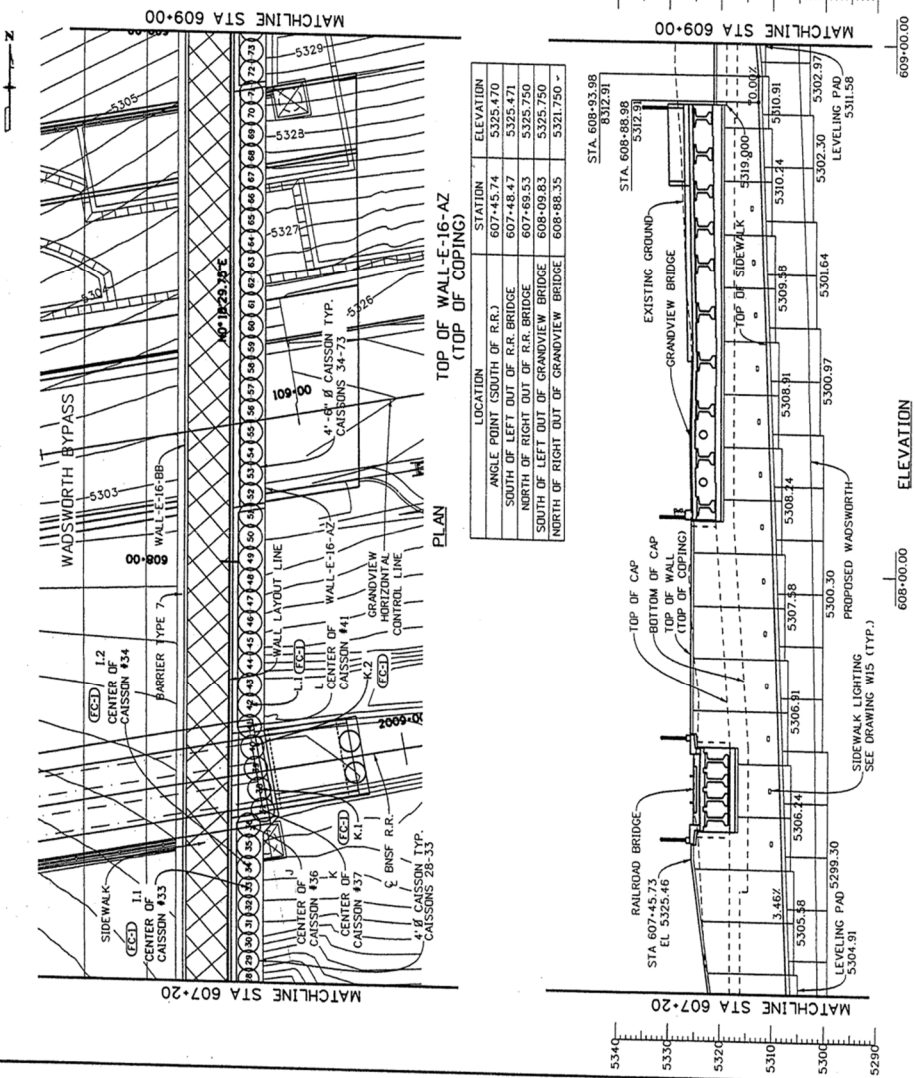

Fig.15.1.12-2 Caisson Wall Section Example

- NOTES:**
- SEE DRAWING W16 & BRIDGE PLANS FOR MORE DETAILS.
 - THE ELEVATION VIEW OF THE WALL IS FROM BEHIND THE CAISSON IN THE DIRECTION OF CAISSON NUMBERING.



CAISSON NUMBER	TOP OF CAISSON ELEVATION	ESTIMATED CAISSON LENGTH (FEET)
28	5316.00	5273.26
29	5316.00	5272.59
30	5316.00	5271.93
31	5316.00	5271.26
32	5316.00	5270.60
33	5316.00	5270.01
34	5314.50	5269.49
35	5314.50	5268.77
36	5314.50	5268.62
37	5314.50	5268.67
38	5314.50	5269.05
39	5314.50	5269.14
40	5314.50	5269.23
41	5314.60	5269.42
42	5315.16	5269.16
43	5315.16	5270.53
44	5315.44	5270.53
45	5315.72	5270.80
46	5315.99	5271.26
47	5316.27	5271.63
48	5316.53	5272.00
49	5316.83	5272.37
50	5317.11	5272.74
51	5317.38	5273.10
52	5317.48	5273.29
53	5317.48	5273.39
54	5317.48	5273.57
55	5317.48	5273.57
56	5317.48	5273.66
57	5317.48	5273.75
58	5317.48	5273.84
59	5317.48	5274.00
60	5317.48	5274.11
61	5317.48	5274.11
62	5317.48	5274.20
63	5317.48	5274.29
64	5317.48	5274.39
65	5317.48	5274.56
66	5317.48	5274.56
67	5317.48	5274.65
68	5317.48	5274.74
69	5317.48	5274.84
70	5317.48	5274.93
71	5317.48	5275.02
72	5317.00	5275.52
73	5317.00	5275.89

POINT	COORDINATES	
	NORTHING	EASTING
L.1	1716427.096	3190663.624
L.2	1716430.846	3190663.644
J	1716433.846	3190663.687
K	1716441.809	3190665.374
K.1	1716445.751	3190665.700
K.2	1716453.637	3190664.352
L	1716457.599	3190663.788
L.1	1716461.599	3190663.810

Fig. 15.1.12-3 Secant Caisson Wall Example

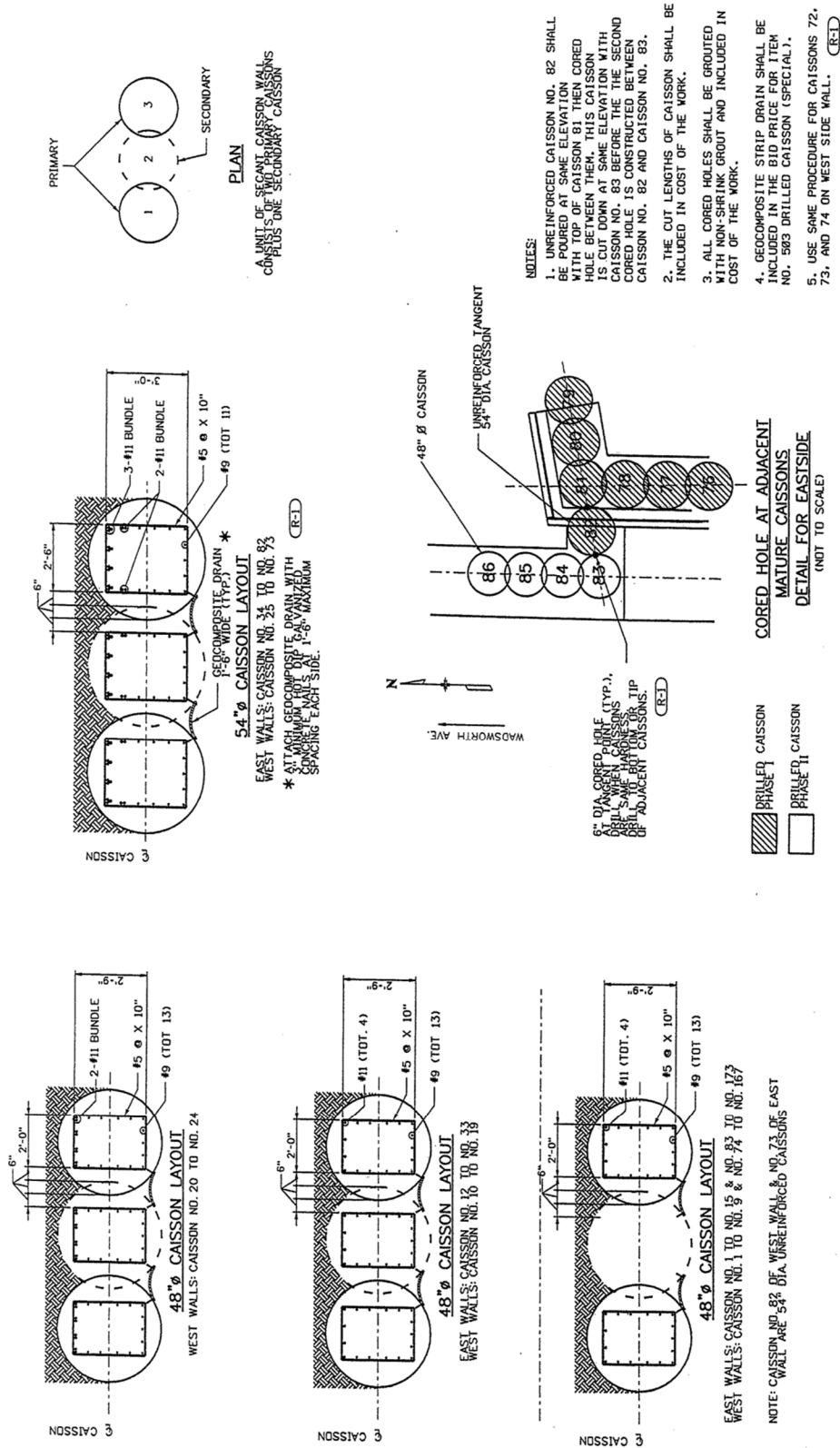

Fig. 15.1.12-4 Secant Caisson Wall Details Example

15.1.13 Sound Barrier Examples & Check Items

Listed below is a summary of items that shall be checked and appear on the drawing in addition to the General Items listed in Section 15.1.8. Additional information may appear as necessary to fully depict required work. The wall examples shown here are a guide only; each wall shall be evaluated for applicability of examples and worksheets on a case by case basis.

CHECK ITEMS

- A) Identify wall material.
- B) Provide access panel details and locations.
- C) Provide caisson/piling spacing details based on wall panel lengths.
- D) Provide cornering details as required.
- E) Provide noise reduction requirements.
- F) Provide height of panel from driving surface.
- G) Verify width of supporting barrier for anchor suitability.

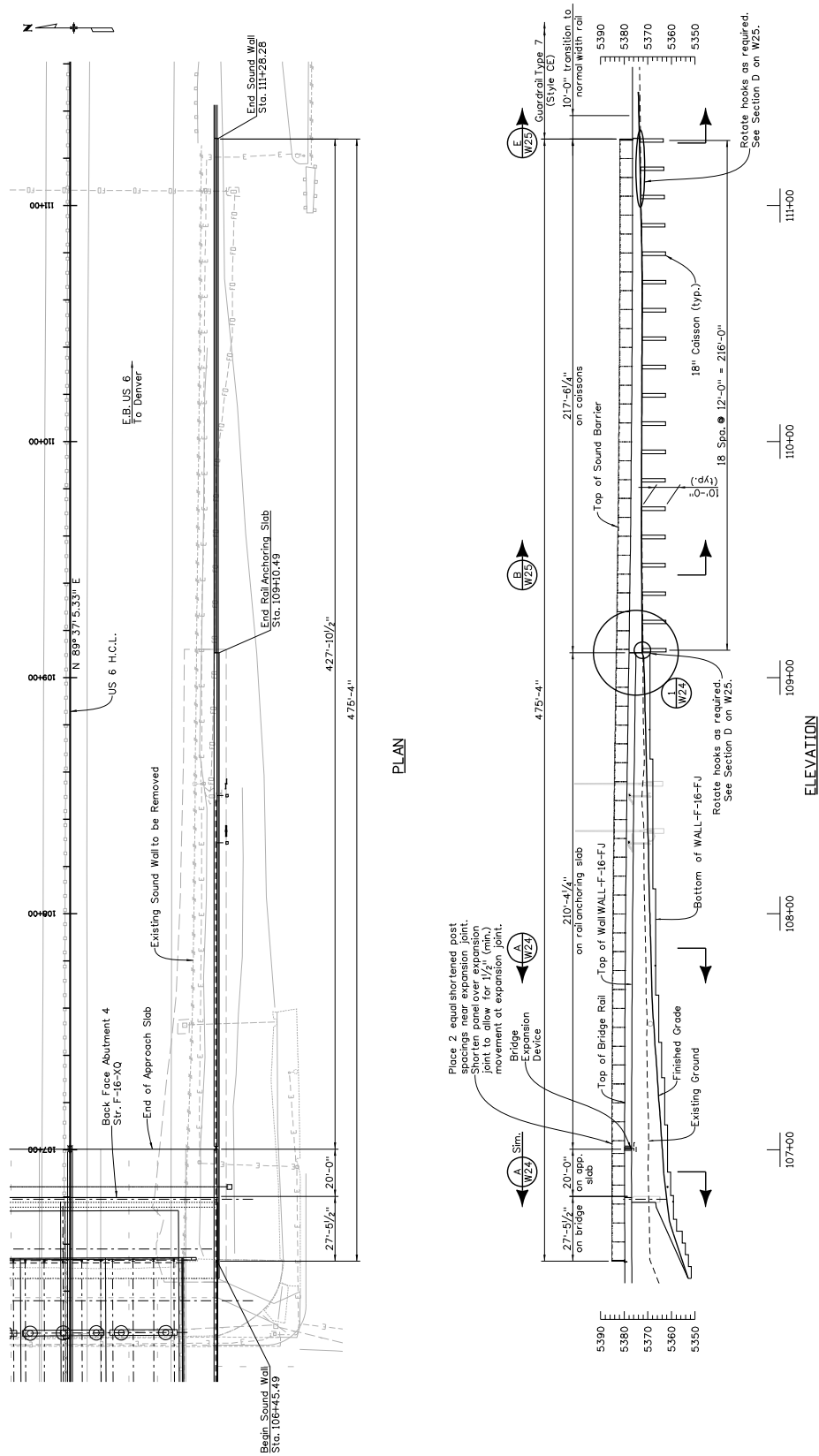

Fig. 15.1.13-1 Sound Barrier Layout Example

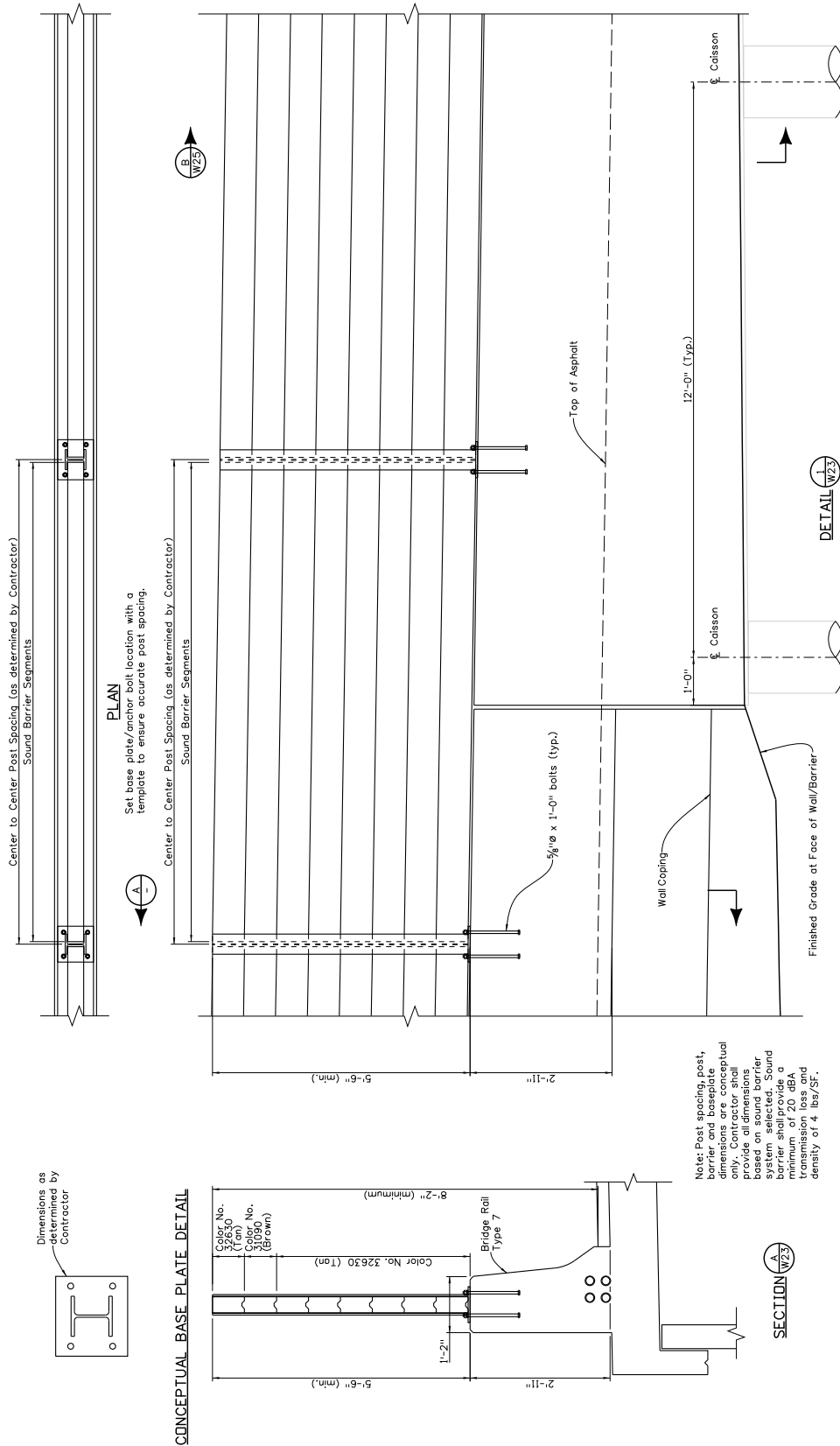
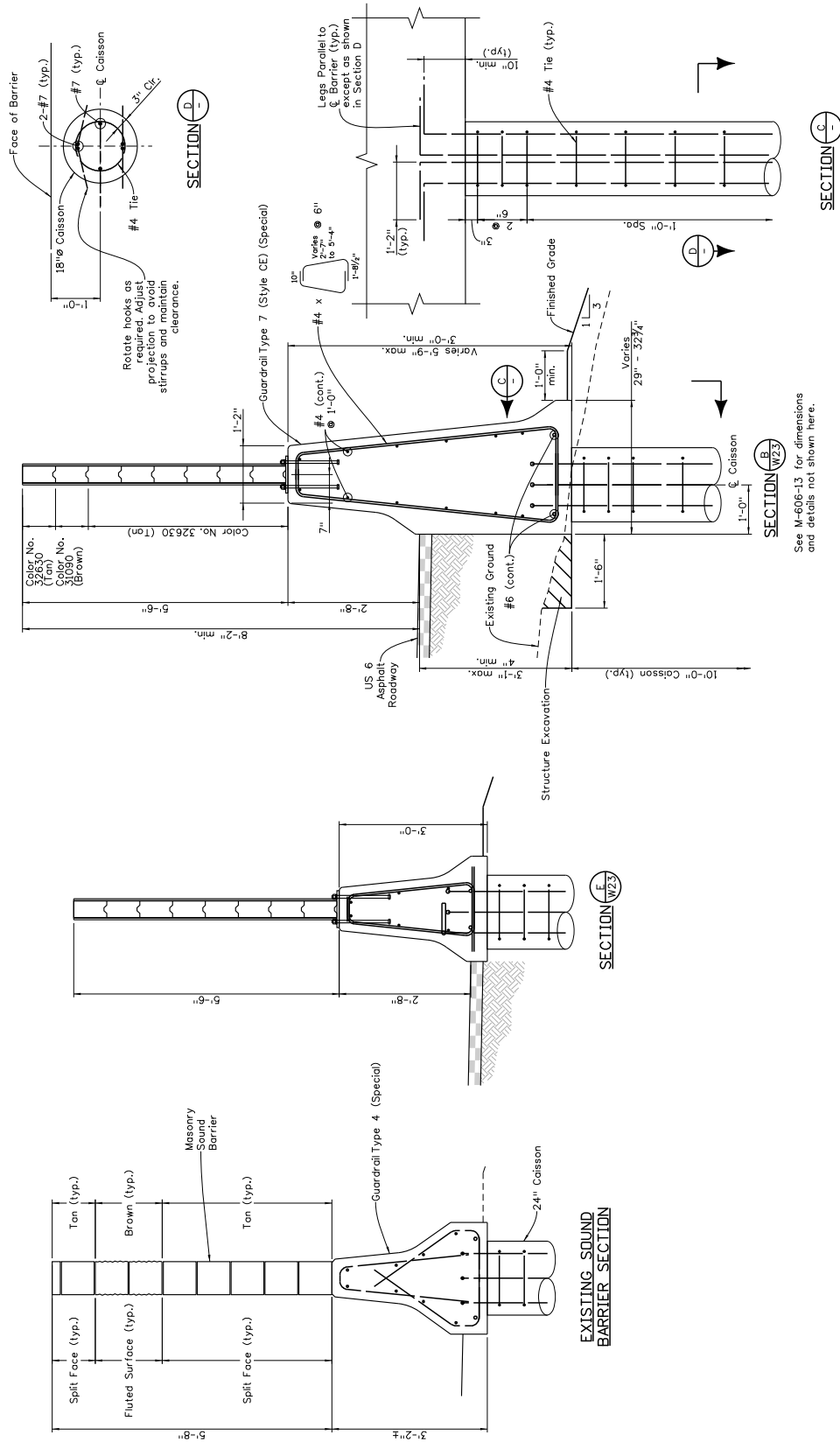

Fig. 15.1.13-2 Sound Barrier on Bridge Example



See M-606-13 for dimensions and details not shown here.

Fig. 15.1.13-3 Standalone Sound Barrier Example

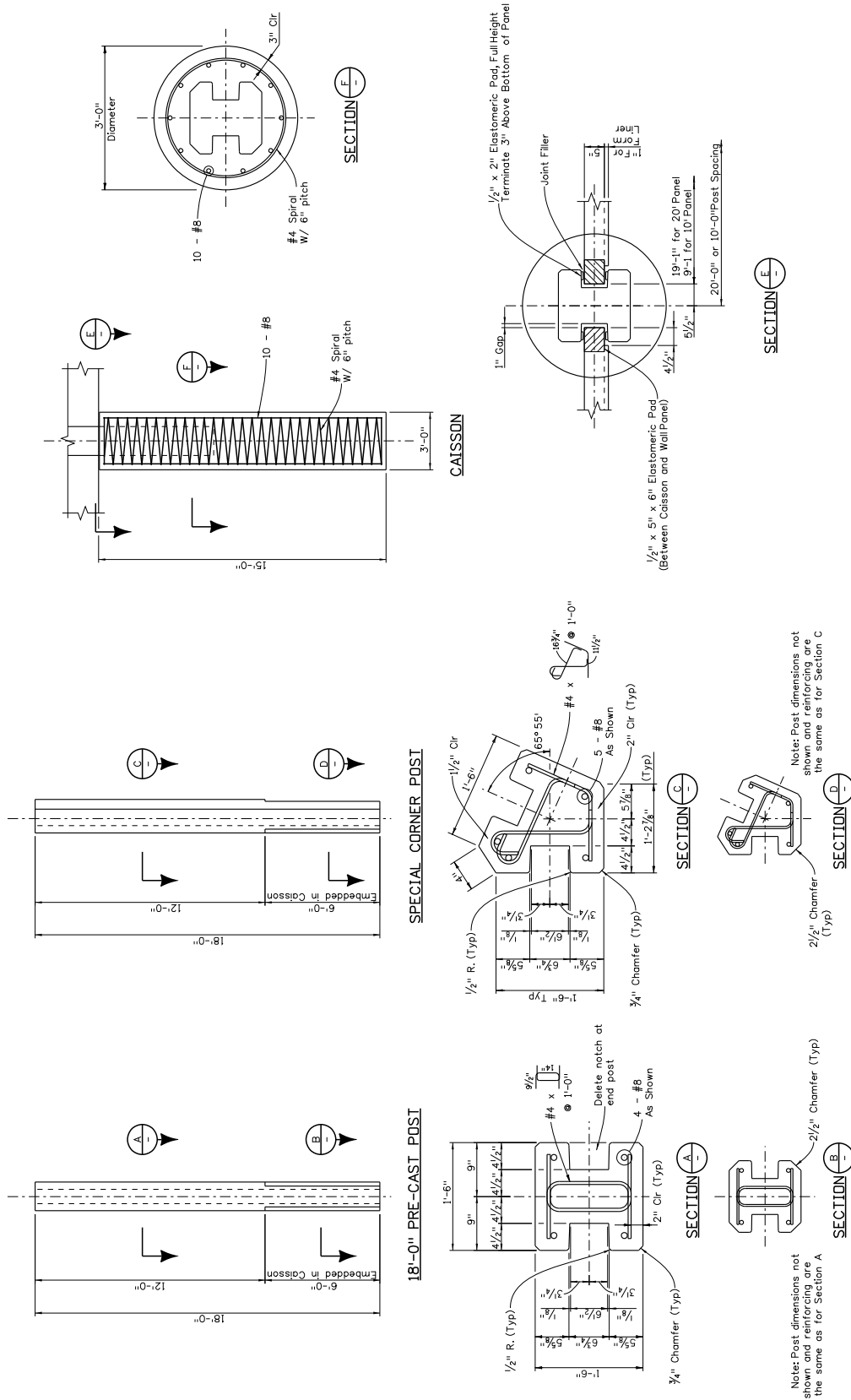

Fig. 15.1.13-4 Corner and Post Details Example

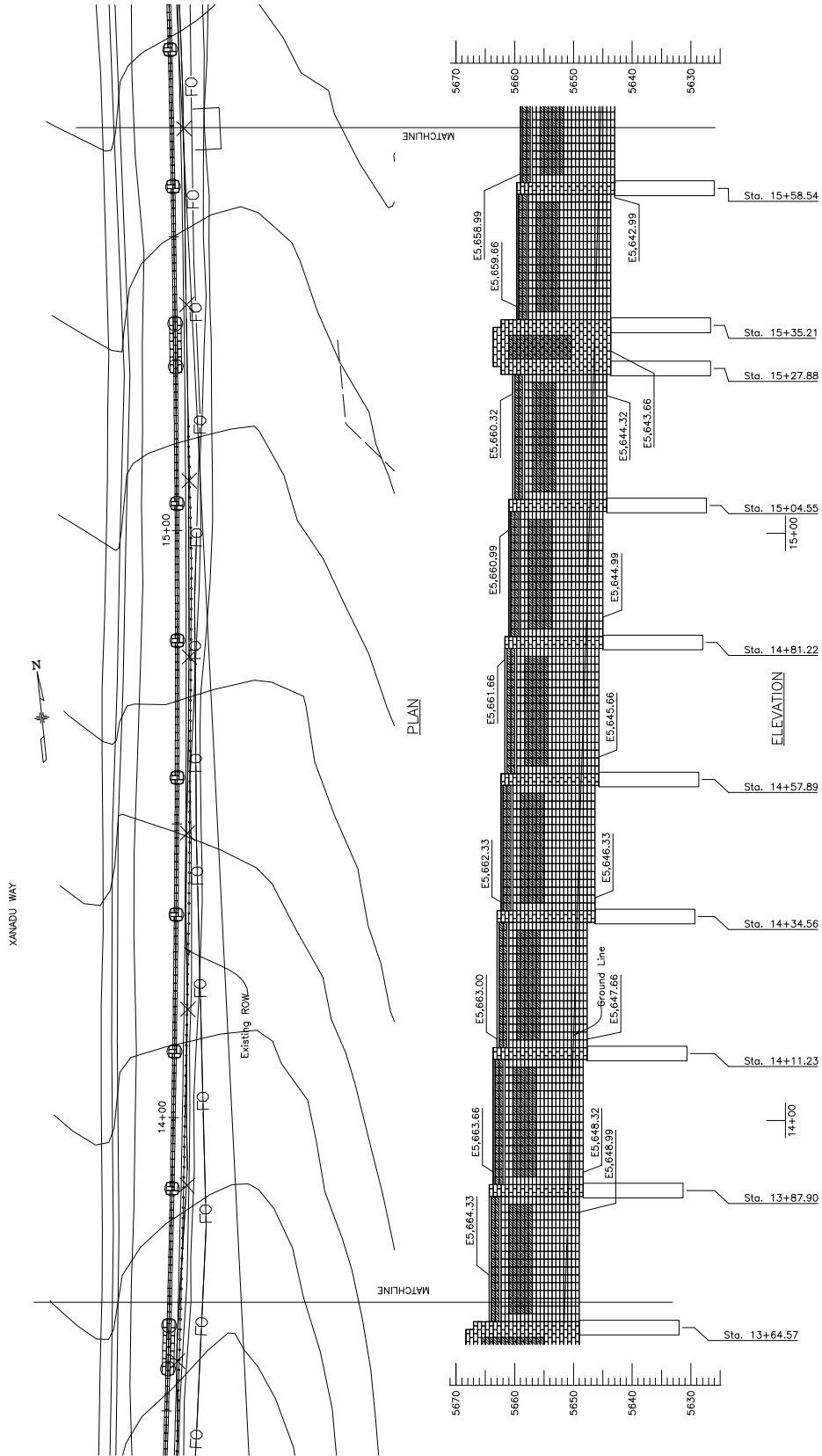

Fig. 15.1.13-5 Masonry Sound Barrier Example

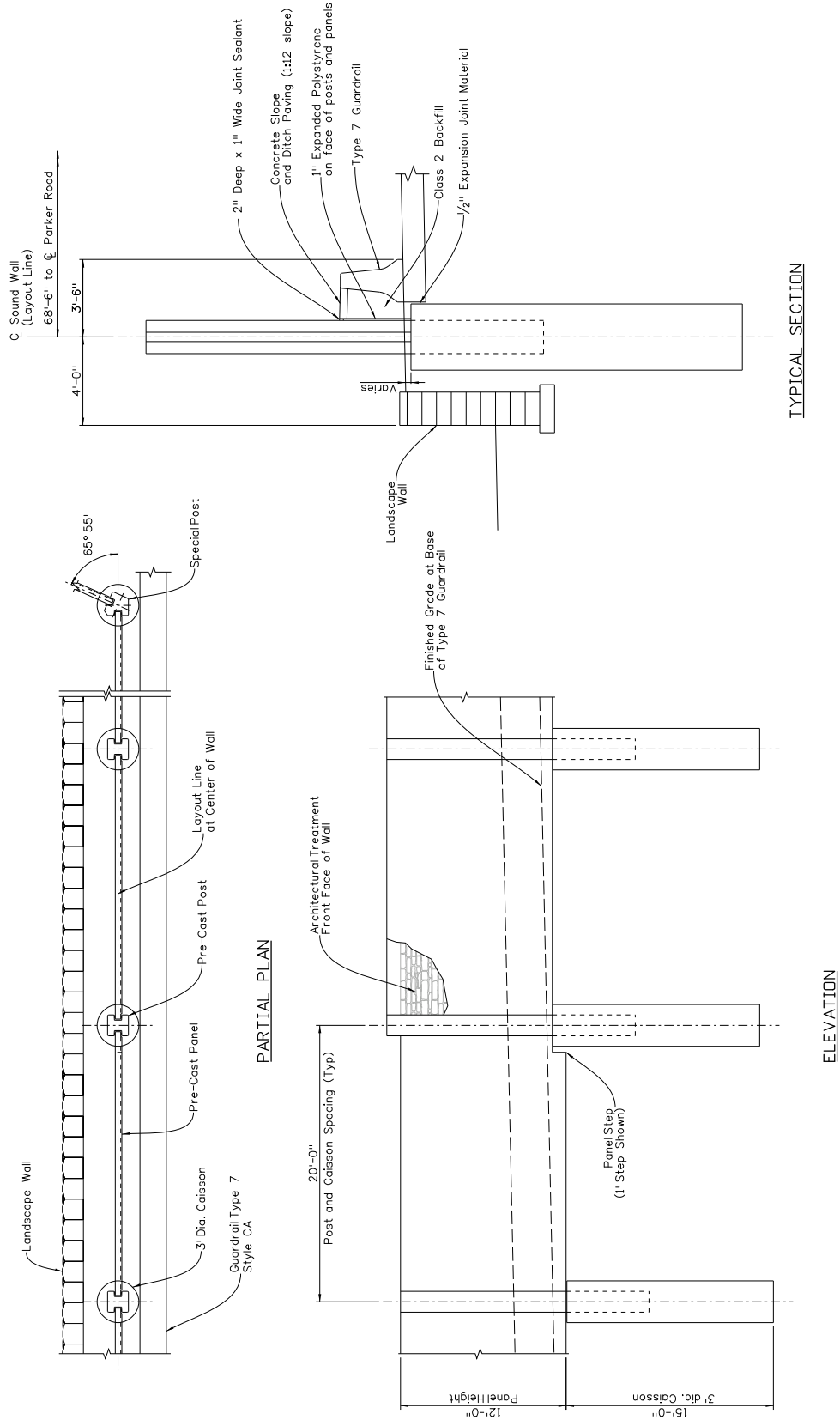

Fig. 15.1.13-6 Precast Panel Sound Barrier Example



Fig. 15.1.13-7 Miscellaneous Sound Barrier Example



Fig. 15.1.13-8 Miscellaneous Sound Barrier Example 2

15.1.14 Sheet Pile Wall and Miscellaneous Examples & Check Items

Listed below is a summary of items that shall be checked and appear on the drawing in addition to the General Items listed in Section 15.1.8. Additional information shall appear, as required. The wall examples shown here are a guide only; each wall shall be evaluated for applicability of examples and worksheets on a case by case basis

CHECK ITEMS

- A) Provide tie back spacing
- B) Provide designation or type of sheet pile
- C) Provide sheet pile and dead-man connection details
- D) Identify soil type (pH and sulfate levels)
- E) Provide required minimum pile tip elevation
- F) Provide drivability and penetration through soil layers
- G) Provide horizontal tolerance and type of coping
- H) Provide corrosion countermeasures
 - I) Provide type of weep hole vs. ground water table
- J) Provide driving plumbness criteria
- K) Provide lateral deformation (counter batter) and requirement of tie-back anchor or dead-man anchor
- L) Note that pre-drill may be required
- M) Provide drainage passage at back face of wall
- N) Depict end of wall treatment
- O) Provide staged excavation in front of wall

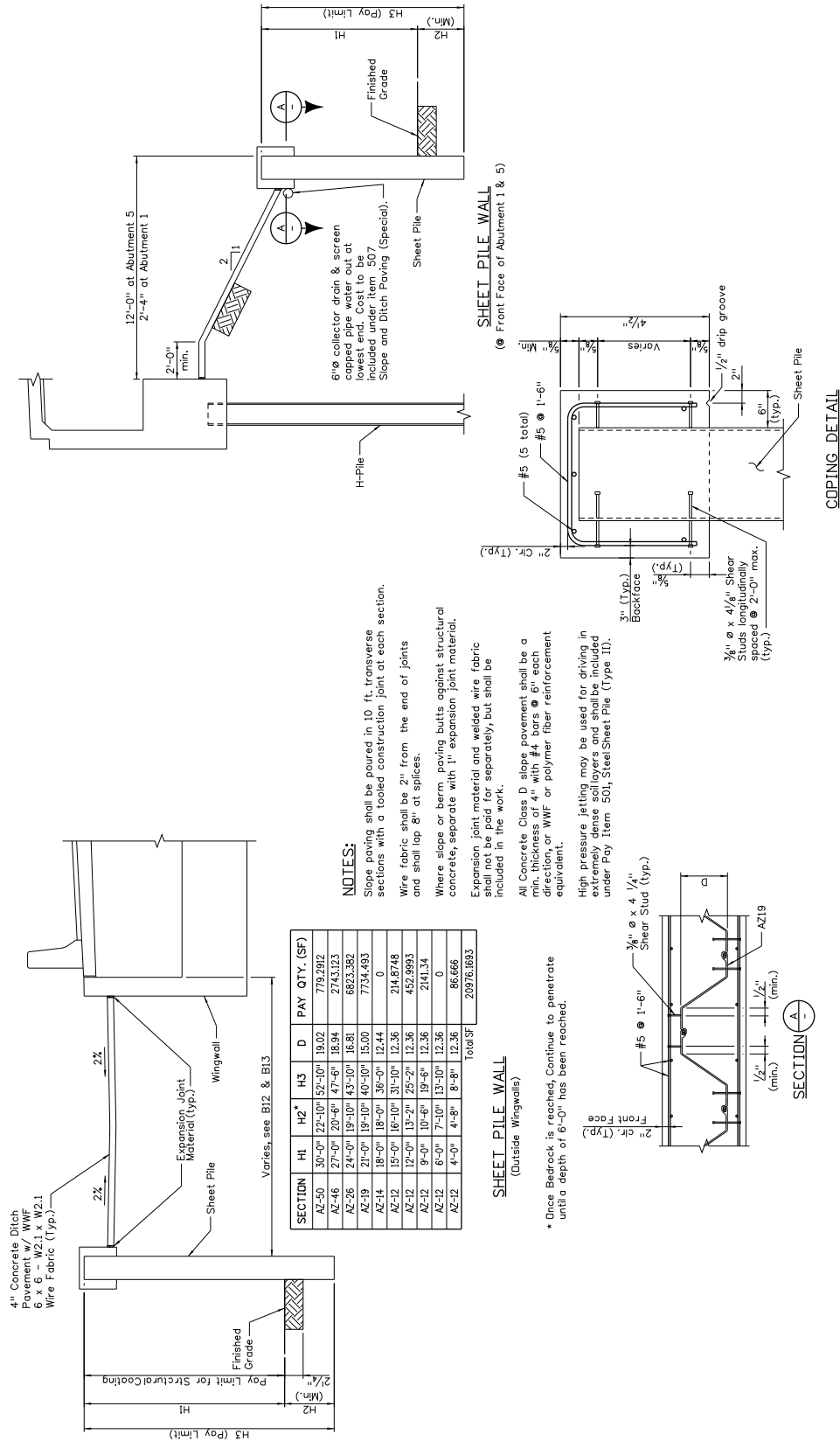

Fig. 15.1.14-1 Sheet Pile Wall Example

